

FEATURES

Baking Quality

- Ceramic heating elements
- Base/Top/Front heating element independent configuration.
- Automatic Damper
High Quality steam

Robustness

- 5 year warranty on Heating elements

Energy Efficiency

- Ceramic heating elements
- High insulation
- ECO and ECU programs

Maintenance

- Easy access to the components
- Few wear elements

Versatility

- Modular configuration adaptable to your needs
- Optional tray sizes
- Pastry, Bakery and Pizza models

Esthetic

- Current and Modern
- Customizable

modular NXE Pizza

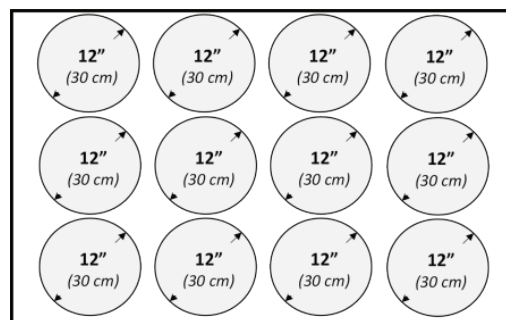

		Power	3 Phases
NXE 1003 P1	208 V	12.6 Kw	32.5 A
	240 V		

Advance

- Touch control
- Easy handling and programming
- 100 programs
- Lighting control key
- Automatic air intake
- Automatic switch-off



E-Future

- Touch control
- Pictograms
- 100 programs · 10 phases
- Independent heating by program
- Intuitive, easy to program and use
- Update and loading of programs by firmware
- Automatic switch-off
- Partial loading
- Easy access to a large quantity of information
- salvaLINK

**All the models are available with independent connection*

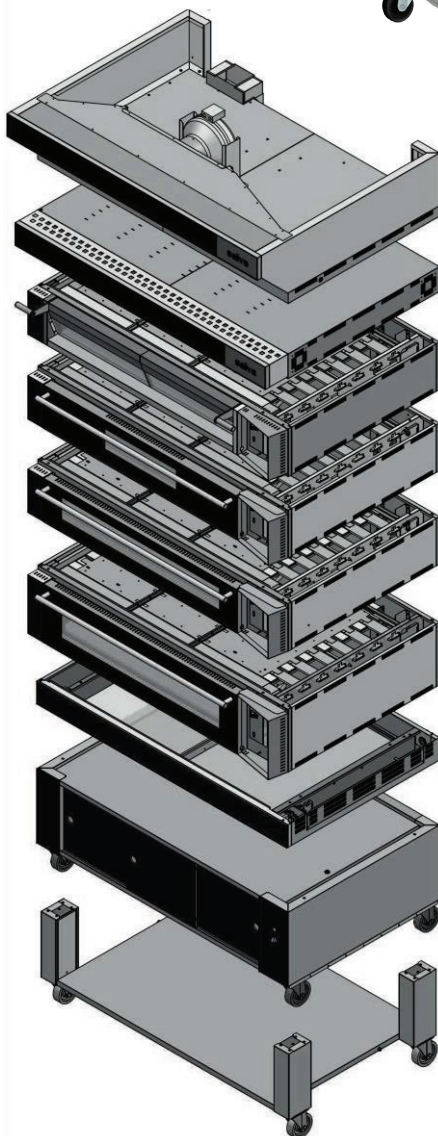

Extraction Hood

H:459 / W: 1912 / D: 1450 mm

TOP (Base/Top)

H:165 / W: 1912 / D: 1331 mm

Bakery Deck 20

H:315 / W: 1912 / D: 1364 mm

Pizza Deck 20

H:315 / W: 1912 / D: 1316 mm

Pastry Deck 20

H:315 / W: 1912 / D: 1316 mm

Pastry Deck 30

H:415 / W: 1912 / D: 1316 mm

BASE (Base/Top)

H:150 / W: 1912 / D: 1167 mm

Proofer

H:704 / W: 1912 / D: 1167 mm

Stand + Wheels

One Deck: 730 + 200 mm

Two Deck: 530 + 200 mm

Three Deck: 435 + 200 mm

Four Deck: 200 + 200 mm

Five Deck: 100 + 200 mm

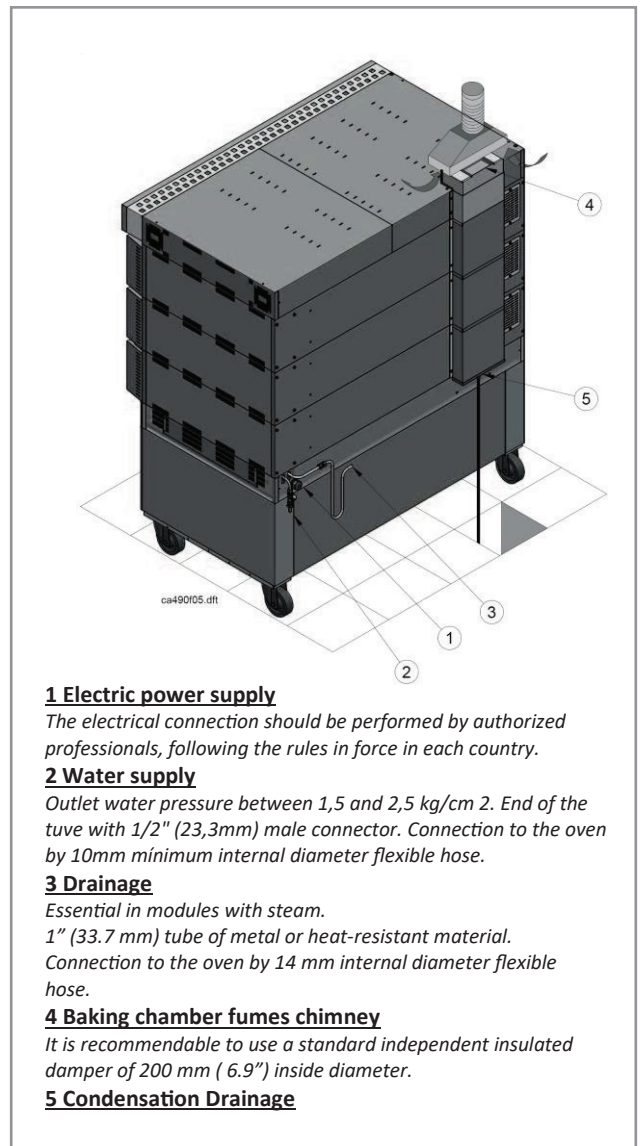

1 Electric power supply

The electrical connection should be performed by authorized professionals, following the rules in force in each country.

2 Water supply

Outlet water pressure between 1,5 and 2,5 kg/cm². End of the tube with 1/2" (23,3mm) male connector. Connection to the oven by 10mm minimum internal diameter flexible hose.

3 Drainage

Essential in modules with steam.

1" (33.7 mm) tube of metal or heat-resistant material. Connection to the oven by 14 mm internal diameter flexible hose.

4 Baking chamber fumes chimney

It is recommendable to use a standard independent insulated damper of 200 mm (6.9") inside diameter.

5 Condensation Drainage